



F-4858	F-4111015E F-411105LE	x P15 - P38M x P151 - P94	- I Prima di iniziare il montaggio, identificare tutti i componenti con l'aiuto delle istruzioni.	
a x 8° x n°1	b x n°6	c x n°6	- GB Before starting to assembly, please identify all components.	
d x n°6	e x n°8	x n°1	- D Vor der montage, sind die Einzelteile anhand der Montageanleitung zu identifizieren.	
x n°1	x n°1	x n°1	- F Avant de débiter le montage, identifiez tous les composants à l'aide de la notice.	
			- E Antes de iniciar el montaje, identifique todos los componentes con ayuda de la nota.	

- I Pezzo di ricambio.
- GB Spare part.
- D Ersatzteil.
- F Pièce en échange / s.a.v.
- E Repuesto

H-A 4858.01 00-0

COMPANY WITH
MANAGEMENT SYSTEM
CERTIFIED BY DNV
ISO 9001 • ISO 14001



Calligaris S.p.A.
Via Trieste, 12
33044 Manzano - (UD) Italy
Tel. +39 0432 748211
calligaris.com
info@calligaris.it

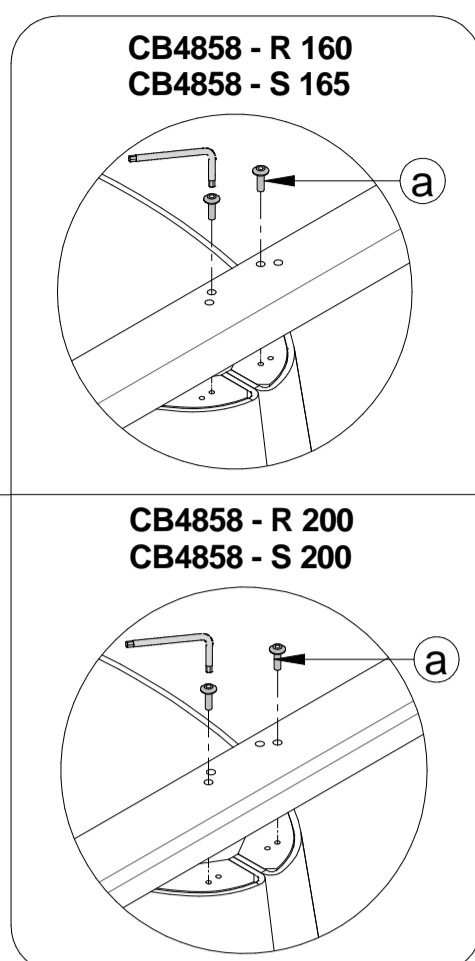
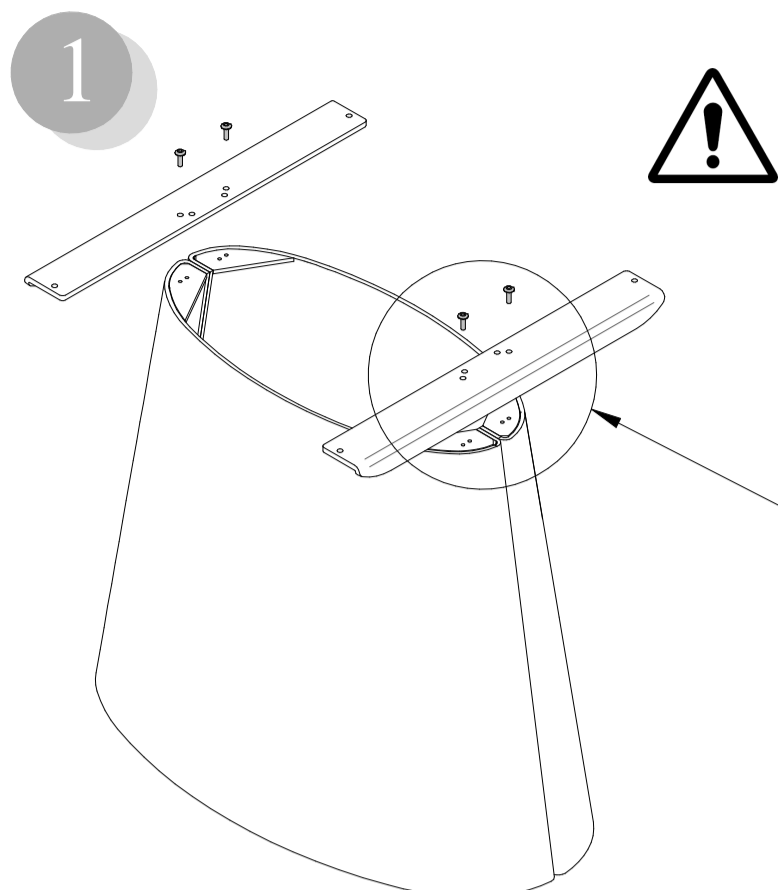

2A CB4858 - R 160
CB4858 - S 165

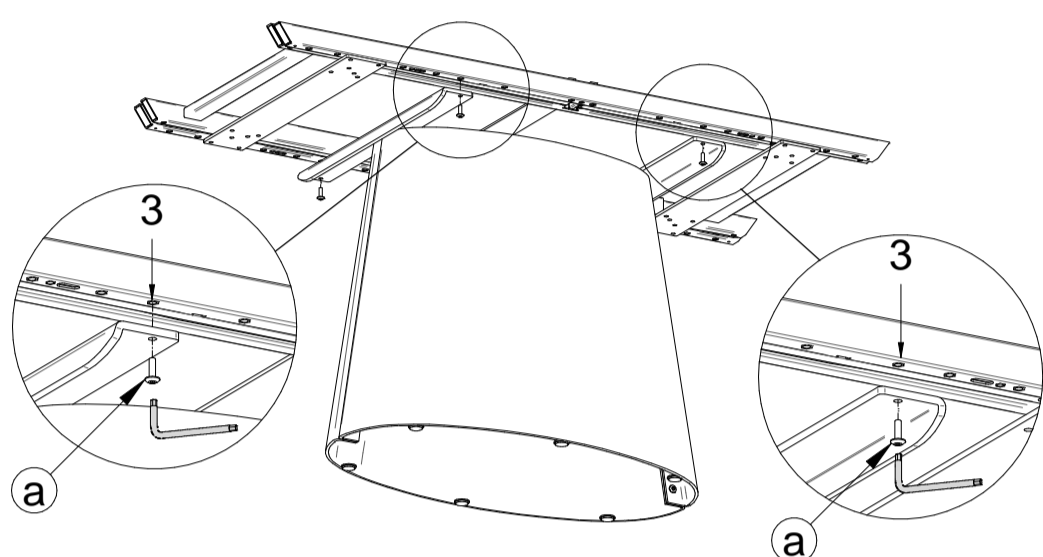
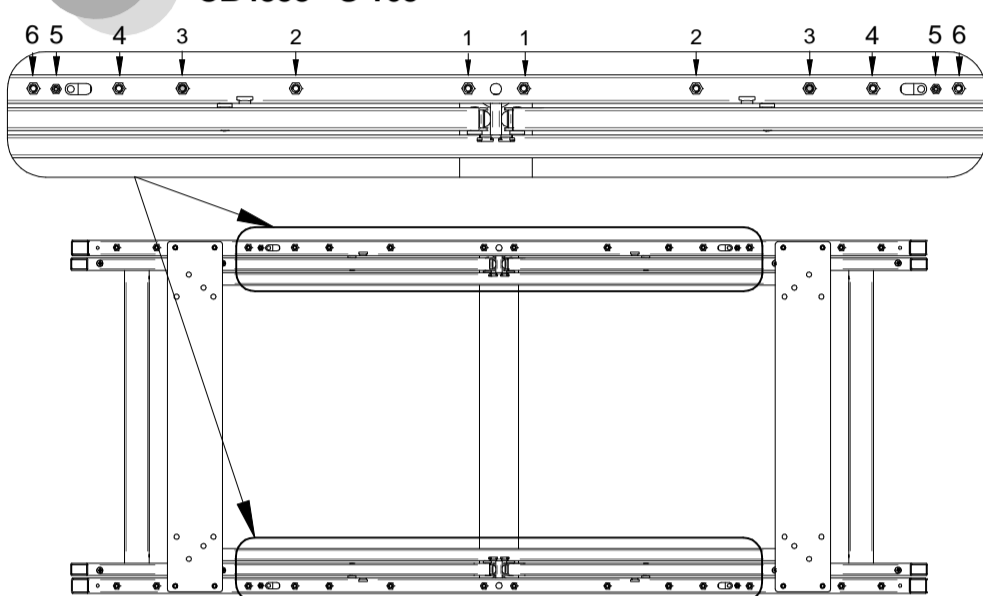

2B CB4858 - R 200
CB4858 - S 200

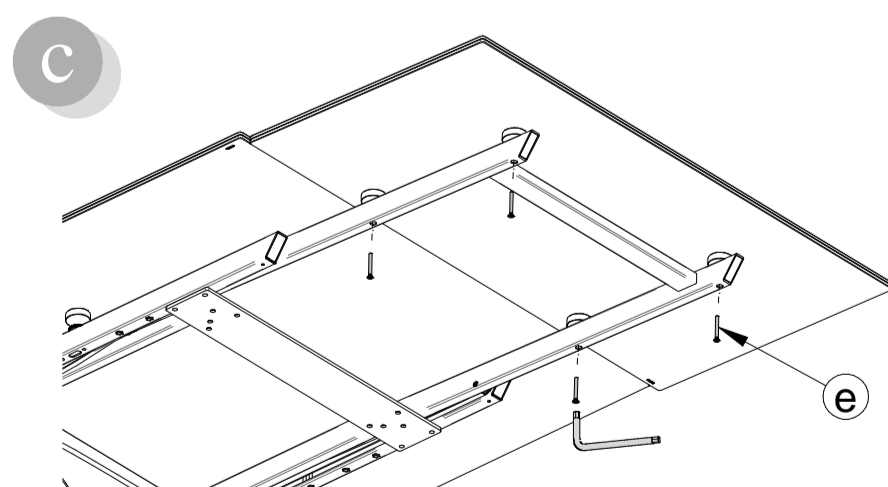
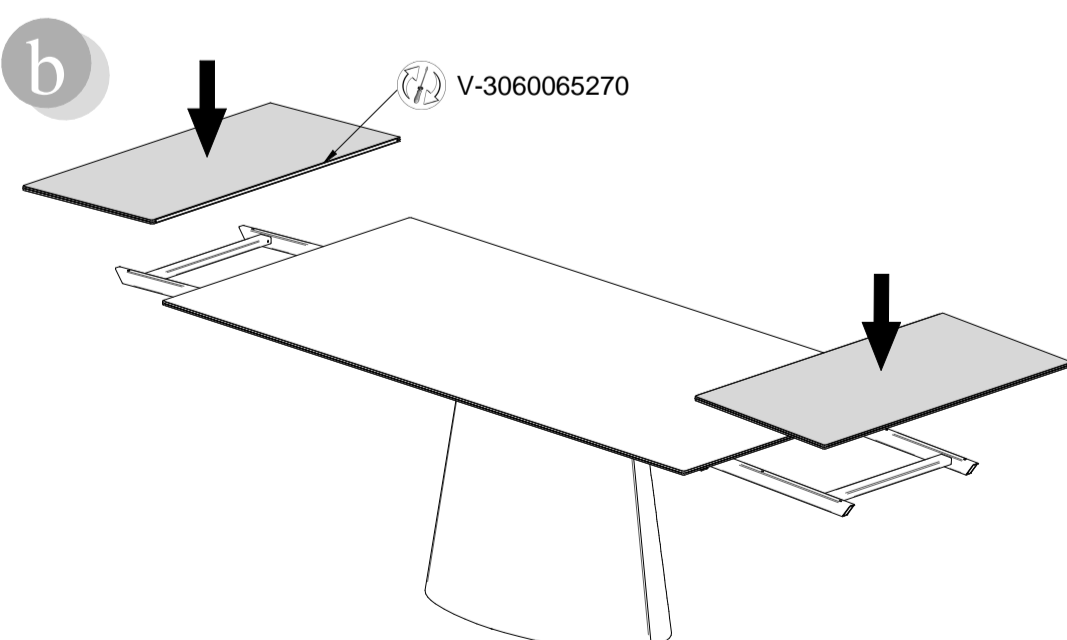
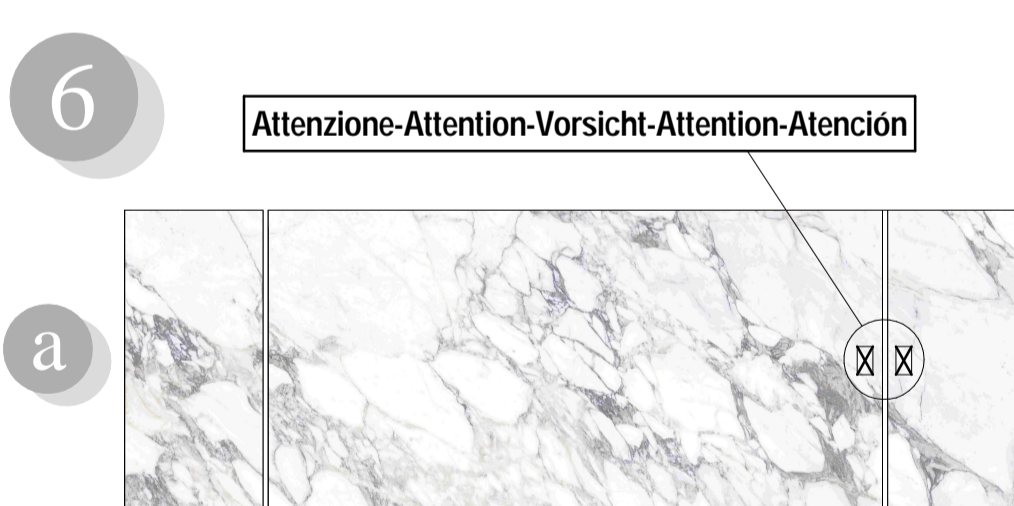
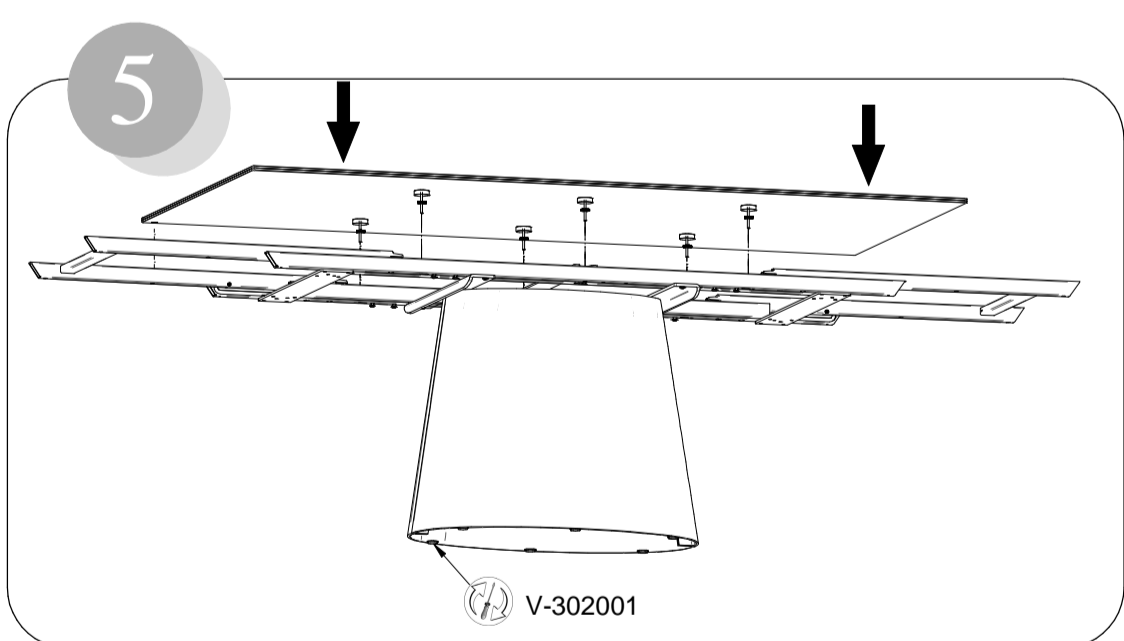
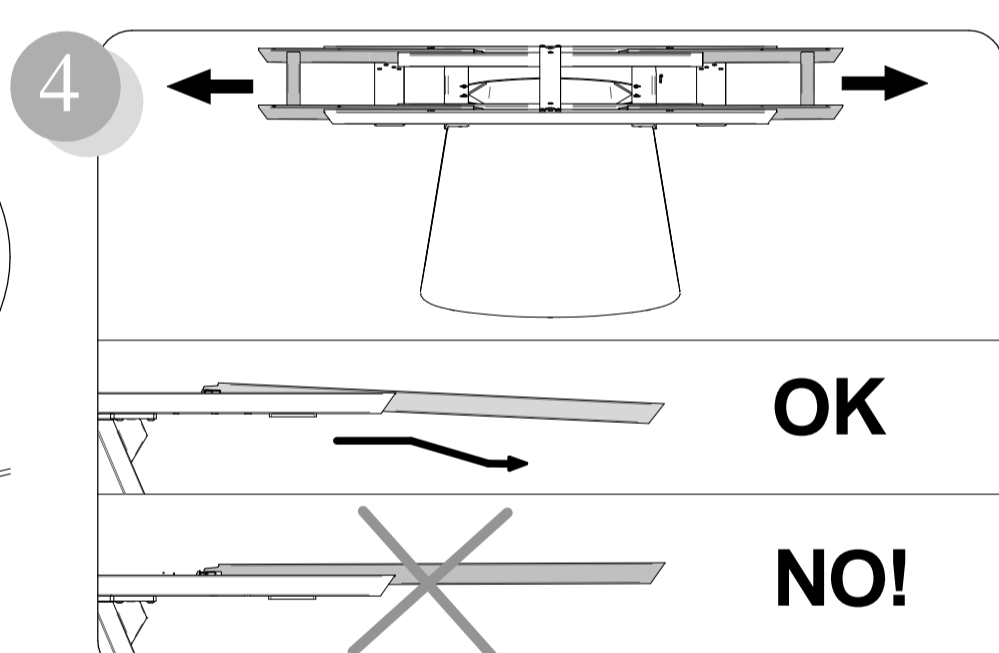
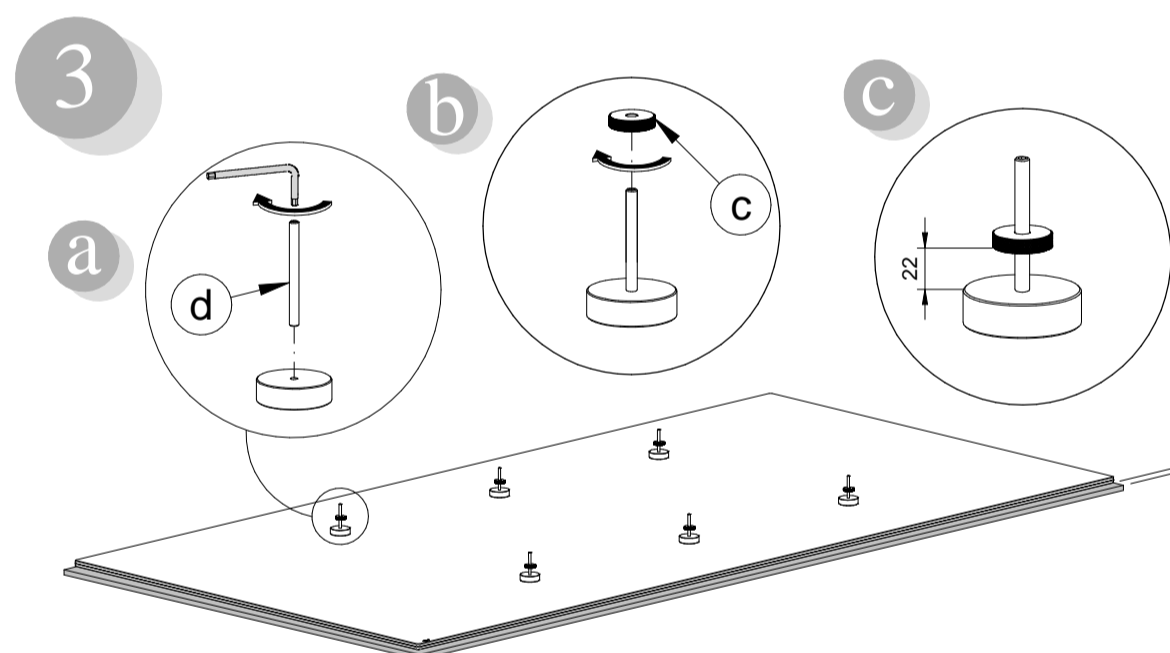
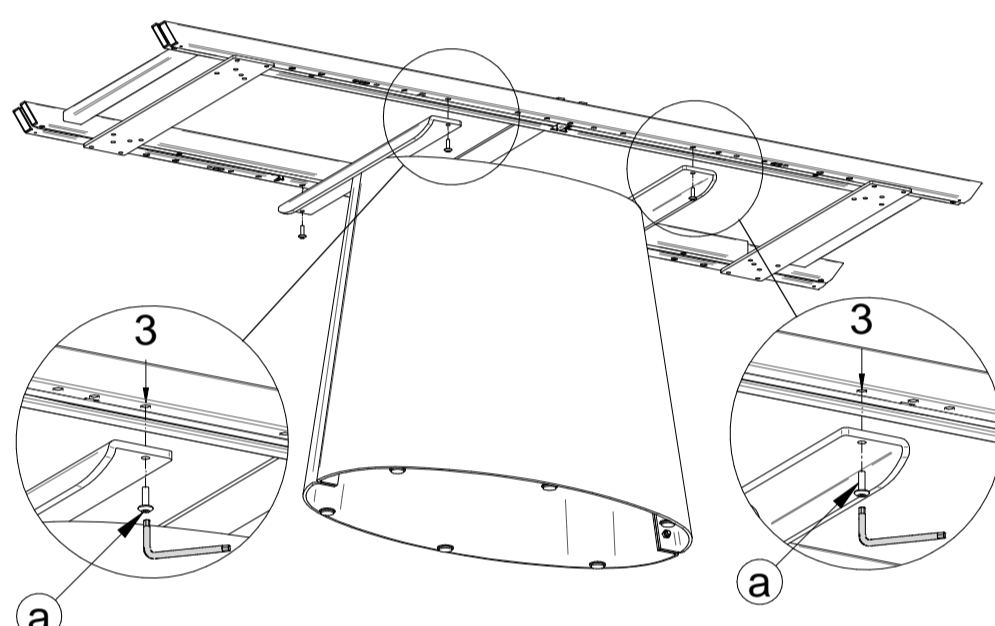
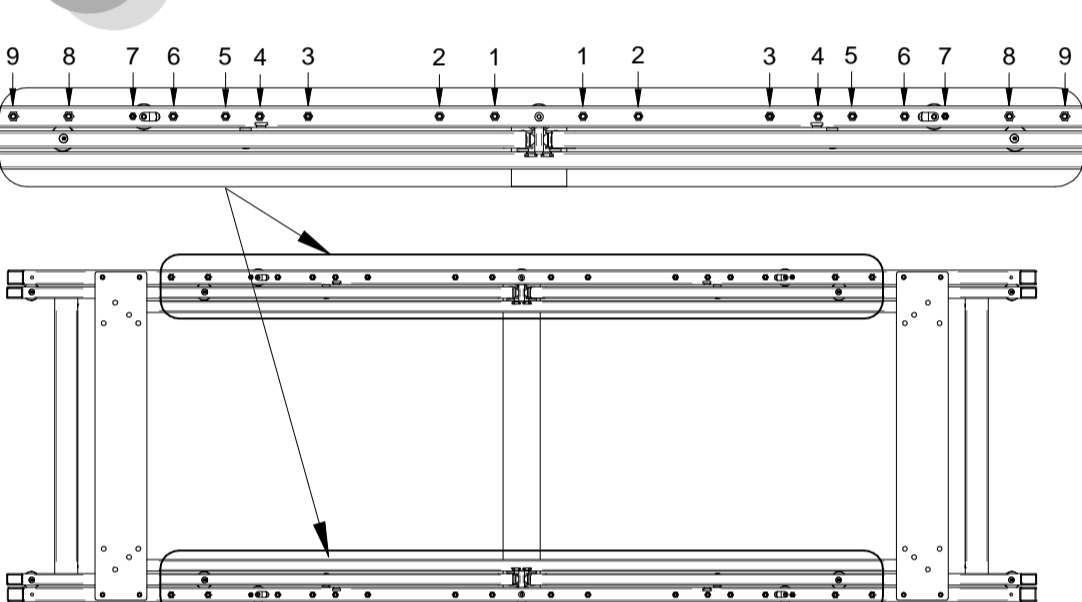

- Attenzione-Attention-Vorsicht-Attention-Atención**
- I Avvitare senza serrare completamente.
 - GB Screw without tightening.
 - D Bitte schrauben Sie alle Schrauben ohne Festzuschrauben an.
 - F Visser sans serrer à fond.
 - E Atornillar sin apretar completamente.

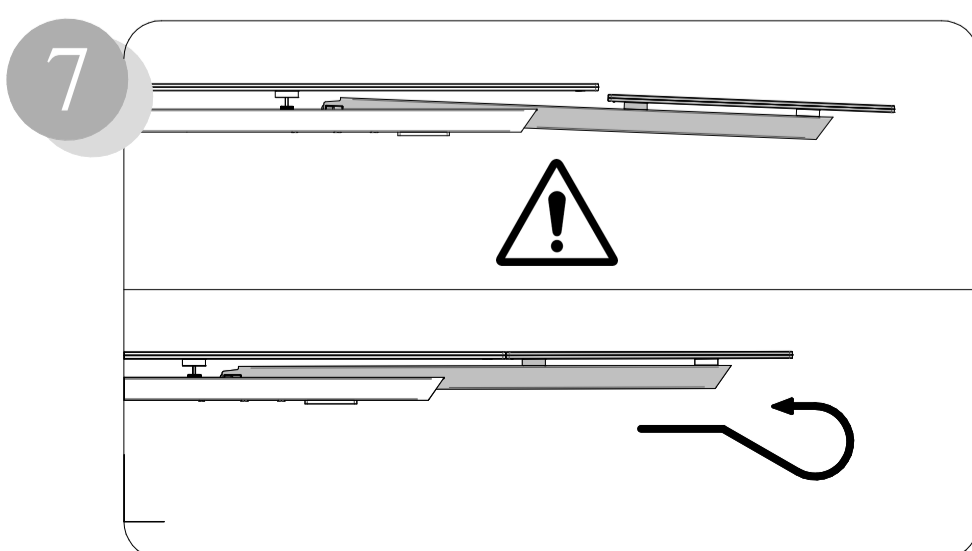

8

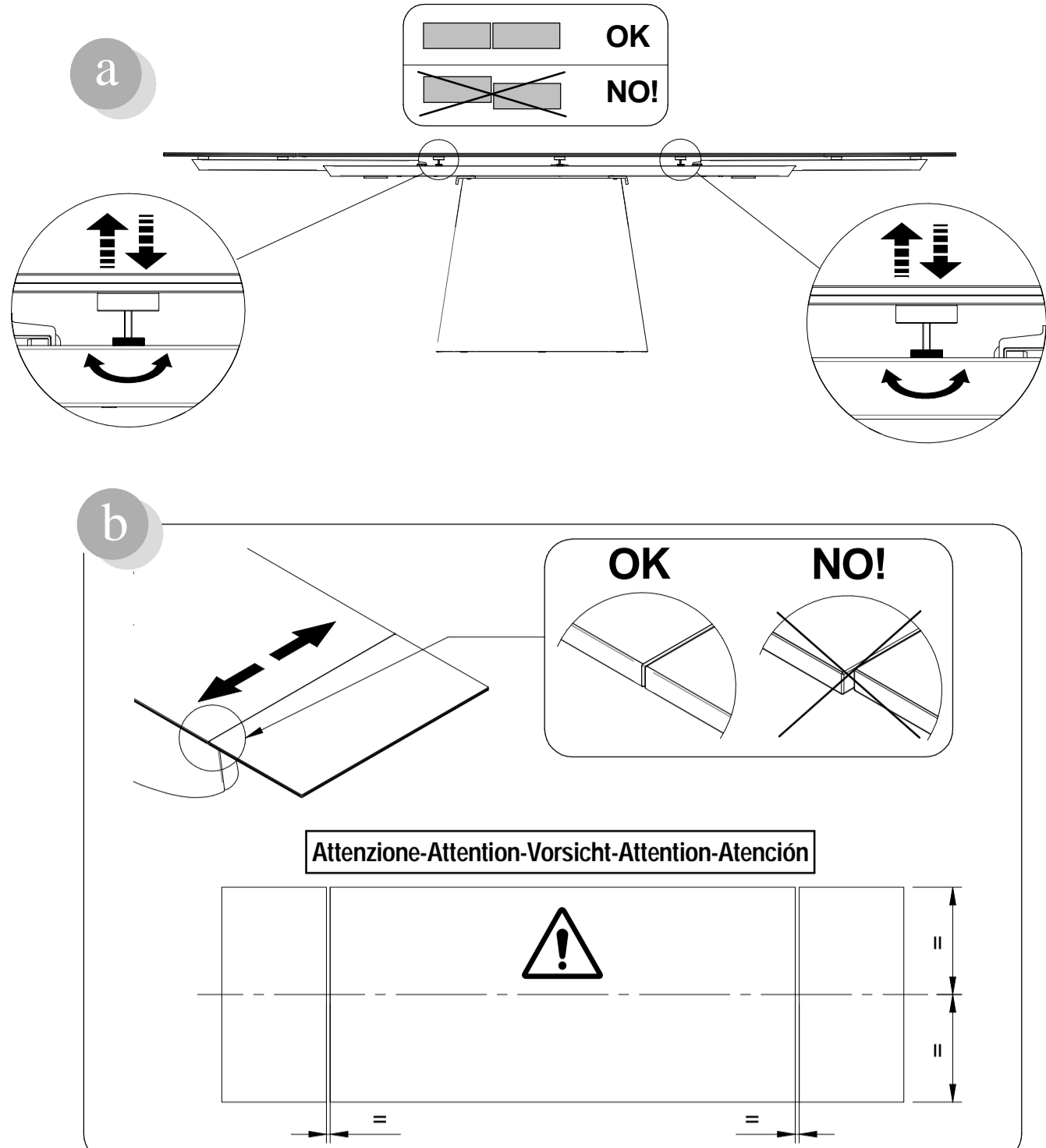

9

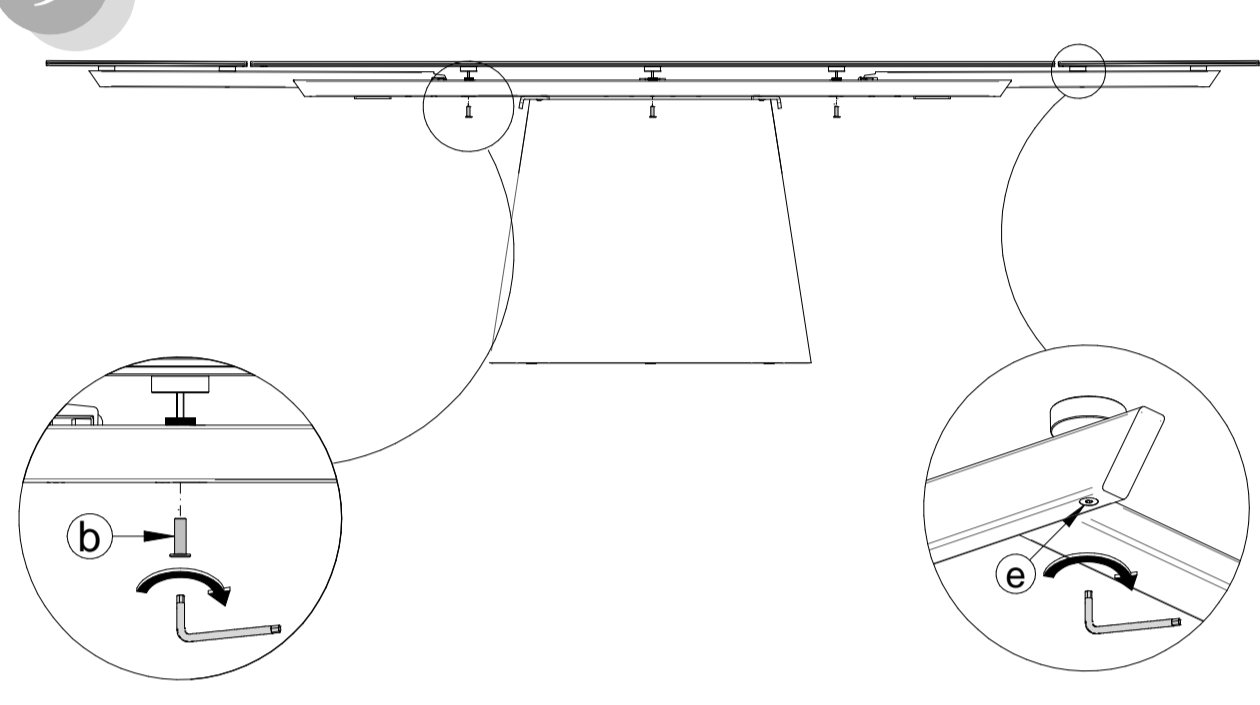

- Attenzione-Attention-Vorsicht-Attention-Atención**
- I Serrare a fondo le viti.
 - GB Tighten the screws strongly.
 - D Fest verschrauben.
 - F Les vis doivent être serrées a fond.
 - E Atrornillar fijamente.

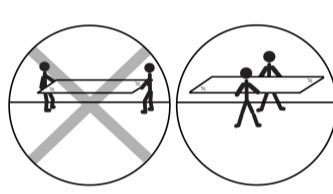

- Attenzione-Attention-Vorsicht-Attention-Atención**
- I Per movimentare il tavolo fare presa sul traverso.
 - GB To move the table grab the crossbar.
 - D Um den Tisch zu bewegen fassen Sie das Querstück.
 - F Pour déplacer la table saisissez la traverse.
 - E Para mover la mesa agarre el travesaño.

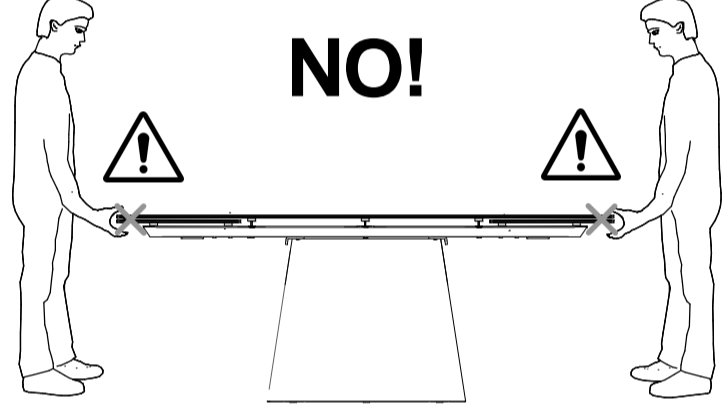

Chiusura-Closing-Verschluss-Fermeture-Cierre

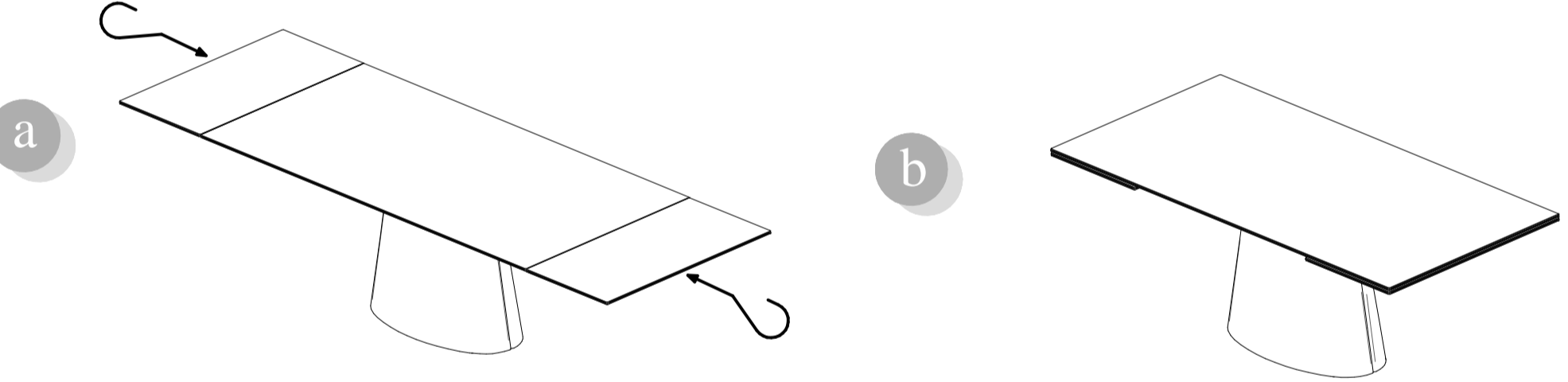

Apertura-Opening-Öffnung-Ouverture-Apertura

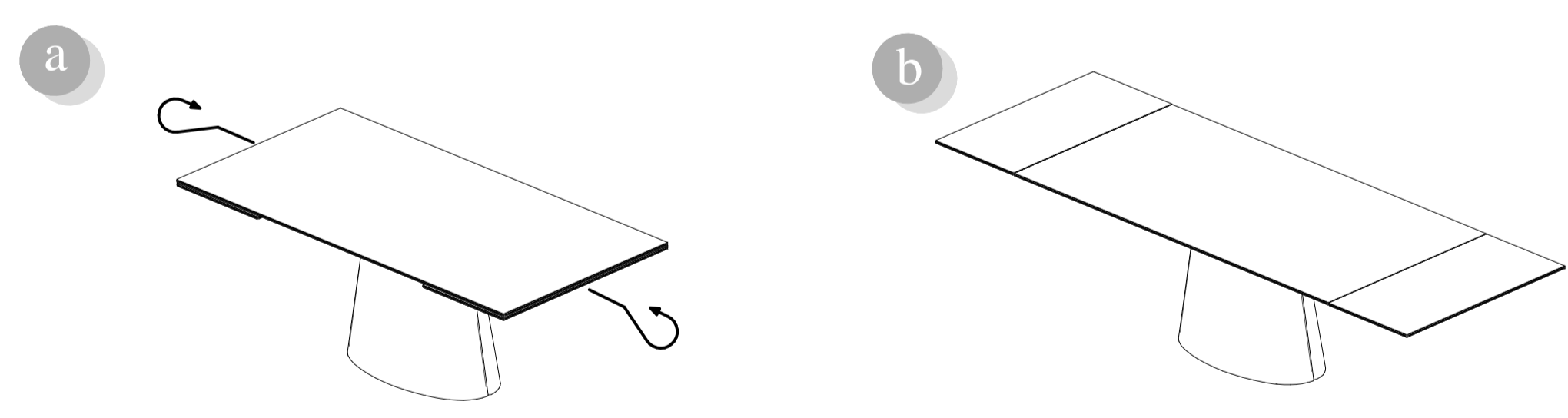

<p>COMUNICAZIONI AL CLIENTE</p> <p>LA PRESENTE SCHEDA PRODOTTO DEVE ESSERE CONSEGNATA AL CLIENTE UNITAMENTE ALLA MERCE ACQUISTATA</p> <p>Tavolo (piastre): 'Ellisse' Modello: CB4858</p> <p>Materiali Struttura in metallo verniciato</p> <p>Istruzioni d'uso</p> <p>Per il montaggio fare riferimento alle relative istruzioni</p> <p>Al fine di garantire la stabilità e la durata nel tempo dell'articolo, si consiglia di verificare periodicamente il corretto serraggio delle viterie</p> <p>Il prodotto non è adatto ad uso esterno</p> <p>Non salire sul tavolo</p> <p>In caso di estensione del piano fare attenzione a non infraporre le dita</p> <p>Il contatto delle superfici del prodotto con corpi caldi può danneggiare il materiale</p> <p>Per interventi di straordinaria manutenzione o di riparazione rivolgersi al rivenditore di fiducia</p> <p>Una volta dismessi il prodotto od i suoi componenti non vanno dispersi nell'ambiente, ma conferiti ai sistemi pubblici di smaltimento rifiuti</p> <p>Consigli di manutenzione</p> <p>I liquidi rovesciati devono essere assorbiti immediatamente con un panno pulito e asciutto</p> <p>Per la pulizia delle parti in metallo, utilizzare esclusivamente prodotti specifici</p> <p>Non usare prodotti abrasivi</p> <p>La Calligaris S.p.a. declina ogni responsabilità derivante da un uso improprio dell'oggetto sopra descritto</p>	<p>CUSTOMER INFORMATION</p> <p>THIS PRODUCT LIST MUST BE DELIVERED TO THE CUSTOMER TOGETHER WITH THE PURCHASED MATERIAL</p> <p>Table (Coupler plate): 'Ellisse' Model: CB4858</p> <p>Materials Structure in lacquered metal</p> <p>User instructions</p> <p>Refer to the instructions for assembly</p> <p>In order to guarantee stability and life of the article, periodically check that the screws are correctly tightened</p> <p>The product is not suitable for outdoor use</p> <p>Do not climb on the table</p> <p>When extending the top, be careful not to trap fingers</p> <p>Contact with hot items can damage the surface</p> <p>For major maintenance or repairs, consult the retailer</p> <p>Once the product or its components are no longer used, make sure that they are disposed of correctly through the public waste disposal services</p> <p>Maintenance recommendations</p> <p>Any spills should be wiped up immediately with a clean, dry cloth</p> <p>To clean metal parts, use products that are specifically for metal</p> <p>Do not use abrasive products</p> <p>Calligaris S.p.a. disclaims any responsibility deriving from incorrect use of the above mentioned object</p>	<p>MITTEILUNG AN DIE KUNDEN</p> <p>DIE VORLIEGENDE KARTE MIT DEN TECHNISCHEN DATEN DES PRODUKTS IST DEM KUNDEN ZUSAMMEN MIT DEM ENGEKAUFENEN PRODUKT ZU ÜBERGEBEN</p> <p>Tisch (Träger): 'Ellisse' Modell: CB4858</p> <p>Materialien Gestell aus lackiertem Metall</p> <p>Gebrauchsanweisung</p> <p>Zur Montage die entsprechende Gebrauchsanweisung konsultieren</p> <p>Zur Gewährleistung der Stabilität und der Beständigkeit des Artikels, ist die regelmäßige Prüfung der korrekten Schraubenbefestigung ratsam</p> <p>Das Produkt ist für die Außenanwendung nicht geeignet</p> <p>Steigen Sie nicht auf den Tisch</p> <p>Beim Ausziehen der Platte ist darauf zu achten, die Finger nicht einzuklemmen</p> <p>Um Schäden vorzubeugen, verhindern Sie bitte den Kontakt der Oberflächen mit heißen Gegenständen</p> <p>Wenden Sie sich für außerordentliche Wartungsarbeiten oder Reparaturen an den Händler Ihres Vertrauens</p> <p>Wenn das Produkt oder seine Komponenten keine Verwendung mehr findet, dann muß es entsprechend über öffentliche Müllsysteme entsorgt werden</p> <p>Wartungshinweise</p> <p>Verschüttete Flüssigkeiten müssen sofort mit einem sauberen und trockenen Tuch entfernt werden</p> <p>Verwenden Sie zur Reinigung der Metallteile ausschließlich Produkte, die speziell für Metall geeignet sind</p> <p>Benutzen Sie keine Schleifmittel</p> <p>Die Calligaris S.p.a. übernimmt keine Haftung bei unsachgemäßem Gebrauch des Produkts</p>	<p>COMMUNICATIONS AU CLIENT</p> <p>LA FICHE PRODUIT DOIT ÊTRE REMISE AU CLIENT AVEC LA MARCHANDISE</p> <p>Table (Plaque de jonction): 'Ellisse' Modèle: CB4858</p> <p>Matériaux Structure en métal verni</p> <p>Instructions</p> <p>Pour l'assemblage voir les instructions</p> <p>Afin de garantir la stabilité et la durée de l'article il est conseillé de vérifier périodiquement le serrage des vis</p> <p>Le produit n'est pas prévu pour l'extérieur</p> <p>Ne pas monter sur la table</p> <p>En cas d'extension du plateau, faire très attention à ne pas se coincer les doigts</p> <p>Le contact de la surface du dessus avec des corps chauds peut endommager le matériel</p> <p>Pour toute intervention d'entretien extraordinaire ou de réparation, contacter le revendeur</p> <p>À la fin de son utilisation, le produit ou ses éléments ne doivent pas être abandonnés dans l'environnement, mais déposés auprès des centres de traitement et d'élimination des déchets</p> <p>Conseils d'entretien</p> <p>Les liquides renversés doivent être absorbés immédiatement avec un chiffon propre et sec</p> <p>Pour le nettoyage des parties en métal, utiliser exclusivement des produits spécifiques pour le métal</p> <p>Ne pas utiliser des produits abrasifs</p> <p>Calligaris S.p.a. décline toute responsabilité en cas d'utilisation erronée de l'objet indiqué ci-dessus</p>	<p>COMUNICACIONES AL CLIENTE</p> <p>LA FICHA DE PRODUCTO DEBE ENVIARSE AL CLIENTE JUNTO A LA MERCANCIA</p> <p>Mesa (Placa de sostén): 'Ellisse' Modelo: CB4858</p> <p>Materialies Estructura en metal lacado</p> <p>Instrucciones de uso</p> <p>Para el montaje seguir las instrucciones al pie de la letra</p> <p>Al fin de garantizar la estabilidad y la duración en el tiempo del artículo, se aconseja controlar periódicamente que los tornillos sean correctamente apretados</p> <p>El producto no es apto para el uso en exteriores</p> <p>No subirse sobre la mesa</p> <p>Poner atención a los dedos al extender la mesa</p> <p>El contacto de la superficie del producto con cuerpos calientes puede degenerar el material</p> <p>En caso de reparaciones o de mantenimiento extraordinario dirigirse al comercio vendedor</p> <p>Cuando se deseché el producto utilizar los canales apropiados</p> <p>Consejos de mantenimiento</p> <p>Los líquidos derramados deben ser absorbidos inmediatamente con un paño limpio y seco</p> <p>Para la limpieza de las partes metálicas, utilizar exclusivamente productos específicos para el metal</p> <p>No usar productos abrasivos</p> <p>Calligaris S.p.a. declina toda responsabilidad derivada de una utilización inapropiada de los objetos arriba descritos</p>
---	--	--	--	--